

## Automated Cup and Tray Filling Machines

The Ohlson Brand Packaging's automatic cup and tray sealing systems allow for the quick and easy filling of trays with various products, including medical devices, hardware, and food products such as snacks, dairy or frozen meals.



### INDUSTRIES



Bakery/  
Confection



Snacks



Bulk Food



Fruits/  
Veggies



Meat/  
Poultry/Fish



Pet  
Food



Pharma-  
ceuticals



Health &  
Beauty

### SAMPLE CONFIGURATION

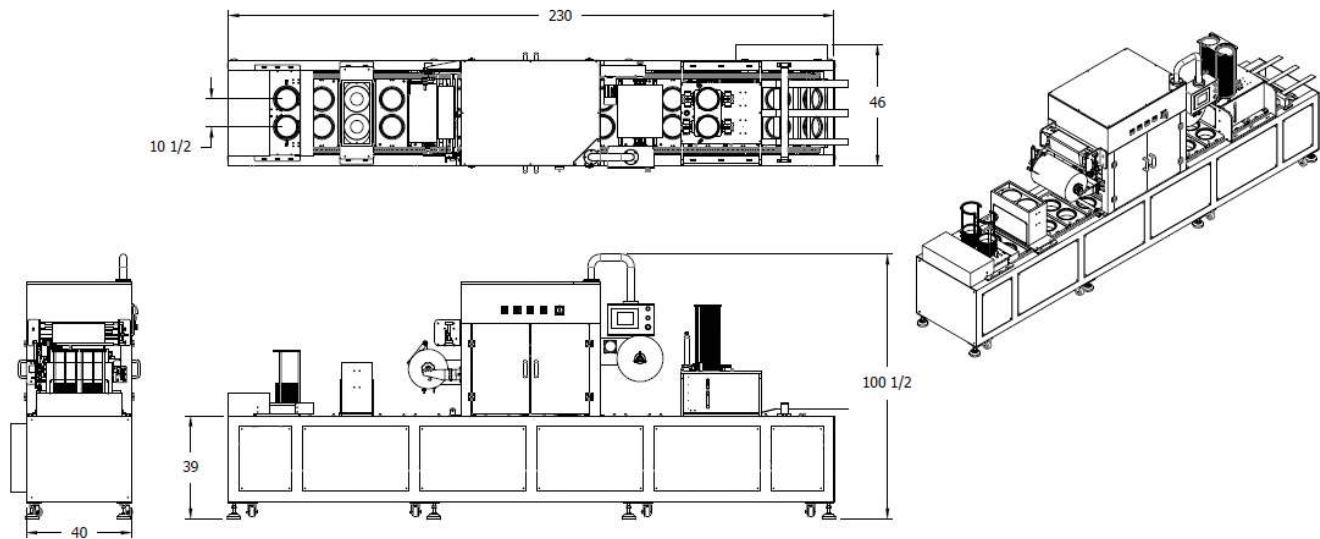

Final layout may vary, LINDEX 50C (2-Lane Model) Depicted

### FEATURES

- Travelling indexing assembly
- Top sealing station with optional gas flush
- Quick tool change for different containers
- Variable speed infeed / discharge conveyor
- No container – no fill sensor
- Safety switches & E-stop
- Stainless steel framework and food grade materials
- Fully adjustable guide rails
- Anti-Vibration Leveling Feet
- Automatic lidding station, shrink banding, date coding, and labeling
- Easy to use color touchscreen operator interface
- PLC Controls

### COMMON ACCESSORIES

- Extra Tooling Assemblies for different containers
- Gas Flush
- Extended Infeed conveyor
- Multihead weigher
- Auger Filler
- Liquid Piston Filler
- Automatic case packing and case shrink system available

### KEY SPECIFICATIONS

Specs may vary based on specific options and/or additional system requirements

	Specifications Per Lane
<b># of Lanes</b>	1-6 Lanes Available
<b>Speed</b>	Up to 20 Containers Per Minute Per Lane (Up to 120/minute for 6-Lane System)
<b>Tray Sizes</b>	2" to 12" Wide
<b>Power Req.</b>	15A 220VAC Three Phase @ 60HZ
<b>Air Req.</b>	18CFM @ 90PSI
<b>Dimensions</b>	230" x 40" x 100.5" (2 Lane System Dim.)

Additional cup/tray filling options for various rigid containers also available.