



NVENIA
A DURAVANT COMPANY

PRE-MADE POUCH FILLING MACHINES

Pre-Made Pouch Filling

Includes Models HOFs 1013, ROFS 1012-SS, ROFS 1012-HS, ROFS 1012-SS-XL

The Ohlson's Brand Pre-Made Pouch Filling Machines come in a variety of models designed to fit with your specific production workflow.

FEATURES

- Stainless Steel Construction
- Centralized Adjustments For Gripper Width
- User Friendly Color Touch Pad
- Bag Magazine
- Bag Opening Blade With Full Opening Detector
- Bag Deflator
- Discharge Conveyor

Note: All features may not be available for all models



COMMON ACCESSORIES

- Dust collector unit
- Date code printer (Bag samples and desired printing locations must be approved)
- Product Settler
- Gas injection
- Zipper opener assist option
- Product deflator chute
- Locking casters
- Timing gate to improve speed
- Liquid pump/valve for liquids and oils (to be deposited into bag)



INDUSTRIES

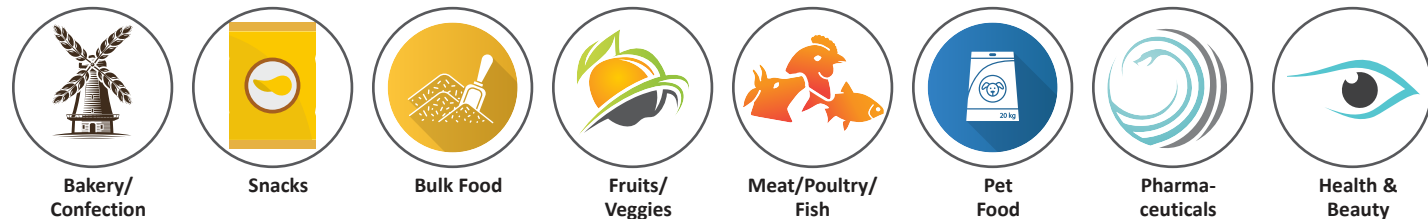

Sample Configuration

ROFS 1012-SS Depicted

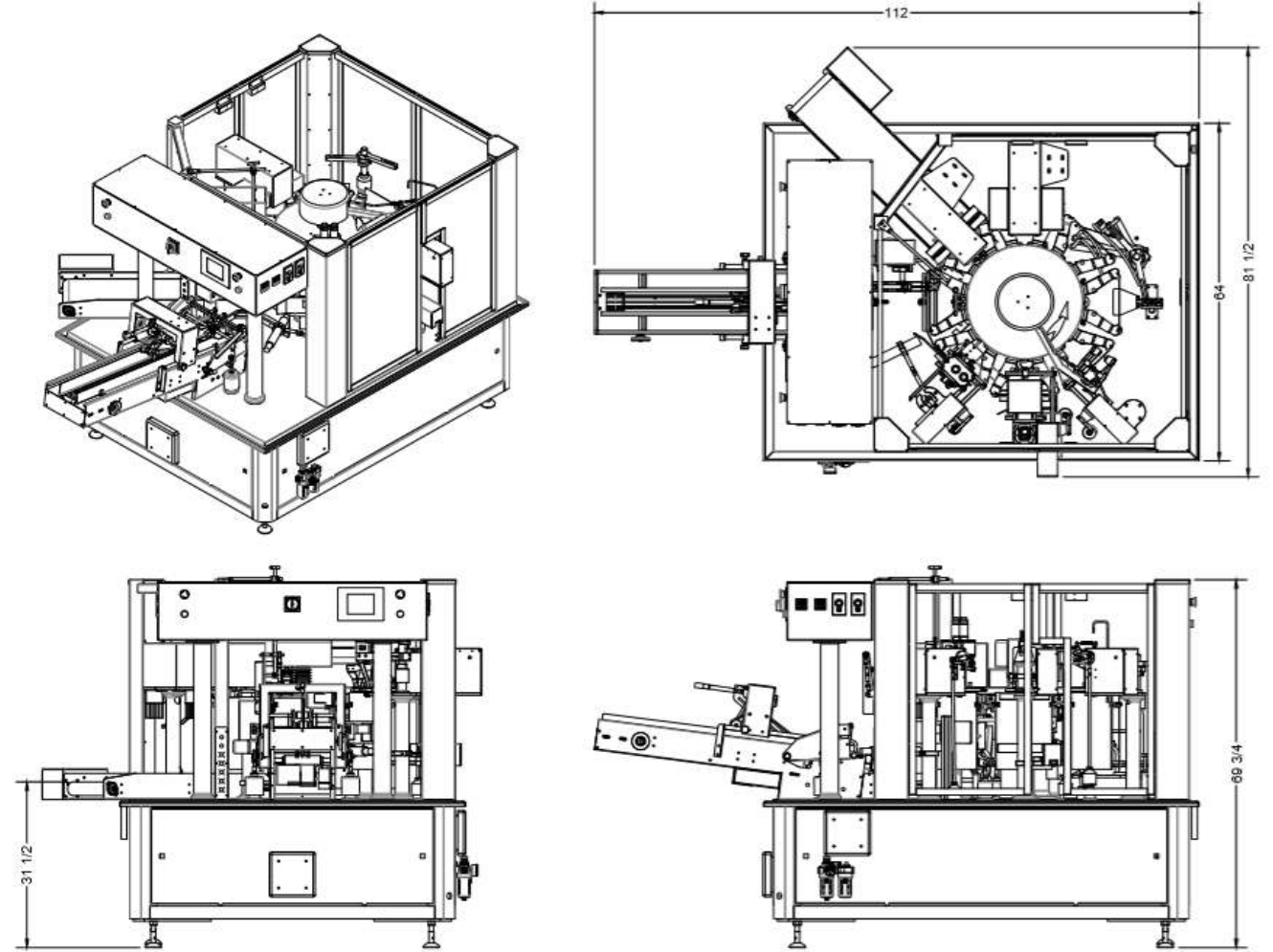

KEY SPECIFICATIONS

Specs may vary based on specific options and/or additional system requirements

	HOFs 1013	ROFS 1012-SS	ROFS 1012-HS	ROFS 1012-SS-XL
Pouch Width	3.9"-10"	4.3" To 9.8"	4.3" To 9.8"	5.9" To 11.8"
Pouch Length	5.5"-13.4"	5.9" To 13.7"	5.9" To 13.7"	7.8" To 17.7"
Max Weight	4.5 lbs	5 lbs.	5 lbs.	10 lbs
Max Speed*	12 Pouches/Minute	35 Pouches/Minute	60 Pouches/Minute	25 Pouches/Minute
Power Req.	15A 220VAC Three Phase @ 60HZ	15A 220VAC Three Phase @ 60HZ	15A 220VAC Three Phase @ 60HZ	15A 220VAC Three Phase @ 60HZ
Air Req.	18CFM @ 85PSI	18CFM @ 85PSI	18CFM @ 85PSI	18CFM @ 85PSI
Dimensions	86" x 70.75" x 60.5"	112" x 81.5" x 69"	112" x 81.5" x 69"	112" x 81.5" x 69"

*Final quoted speeds are product and weight-dependent

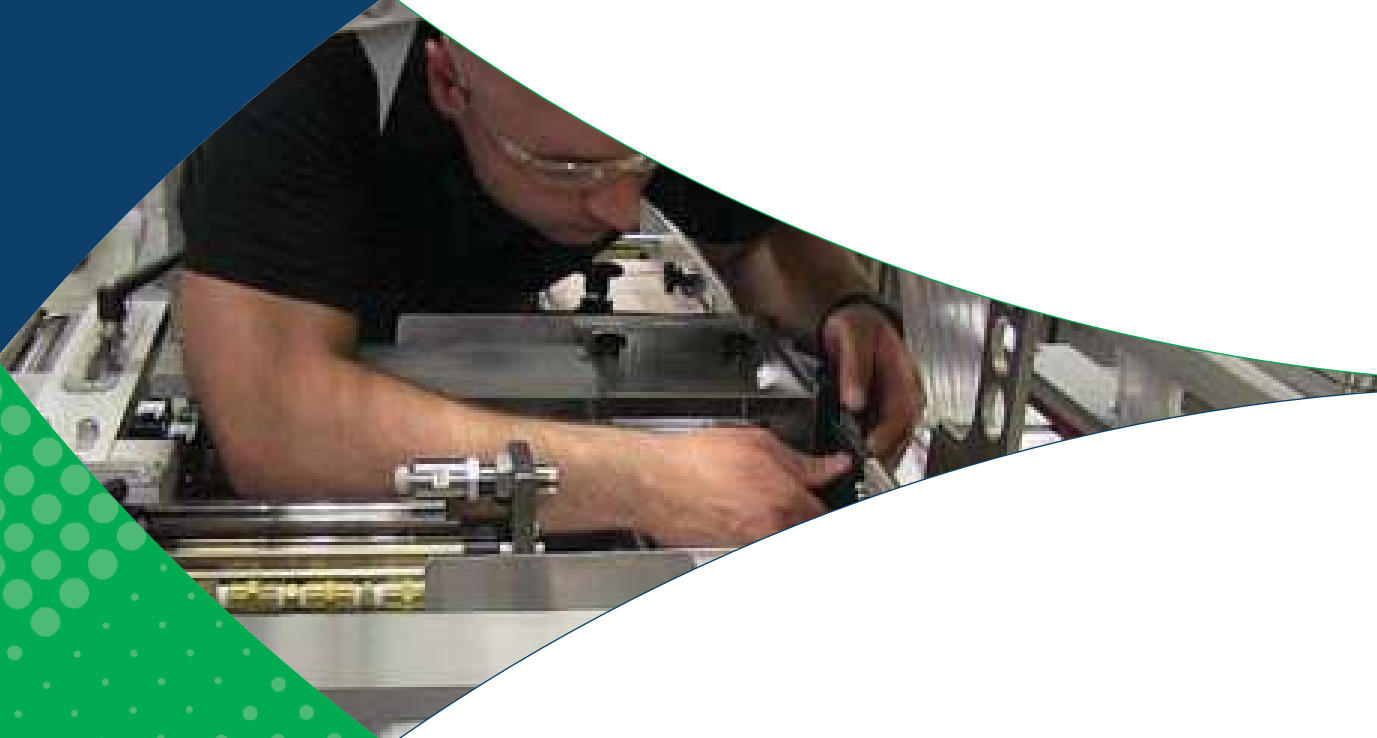

NVENIA

750 N. Wood Dale Road
Wood Dale, IL 60191
info@nVenia.com
800.253.5103
www.nVenia.com

SUPPORTPRO

3500 Lacey Road, Suite 290
Downers Grove, IL 60515
support@supportpro.pro
844.777.8776
www.supportpro.pro