

XL Shrink Wrapper

Our ARPAC Brand EXTREME XL models are workhorses in the industry, featuring a proprietary design that provides fast, user-friendly and reliable operation. This flexible L-bar design is guaranteed to provide you with high quality packaging for retail display. The development of the L-bar wrapper is packaging innovation at its finest, featuring a simple and functional design for easy automation.



XL18

APPLICATIONS

- Automotive
- Beverage
- Building Supplies
- Consumer Goods
- Contract Packaging
- Food
- Health & Beauty
- Material Handling
- Printing & Publishing

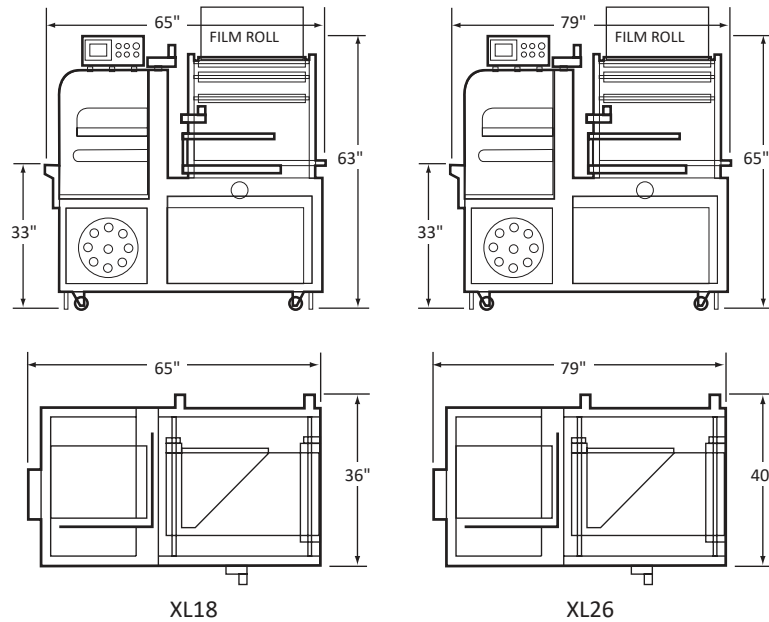

FEATURES

- Welded steel frame in a compact size for space efficiency
- Guillotine style hot knife seal bar design - straight pull vs. cantilever ensures highest quality seal
- Single point adjustment seal height with stroke-limiting automatic seal cylinder
- Seal height calibration automatically determines proper seal head cushioning
- Configurable PLC with color touchscreen interface
- Easy load film cradle with on demand powered film feed
- Film pinch roller positioned ahead of seal head eliminates film breaks/tears
- Adjustable legs with casters

OPTIONS

- Closing conveyor for short length product
- Lower film cradle for ergonomic loading
- Reverse flow (L to R)
- Food approved infeed and discharge belts

SPECIFICATIONS

- Max speed: 35 packages per minute
- Electrical power requirements: 220 VAC, 1 Ph, 60 Hz
- XL18 electrical power requirements: 220 VAC, 1 Ph, 60 Hz
- XL26 electrical power requirements: 220 VAC, 1 Ph, 60 Hz
- Compressed air requirements: 80 psi, 5 SCFM
- XL18 machine dimensions: 40" W, 65" L, 63" H
- XL18 shipping weight: ~1,200 lb
- XL26 machine dimensions: 46" W, 79" L, 65" H
- XL26 shipping weight: ~1,600 lb

PACKAGE SIZE RANGE

- XL18 product range:
Min: 1.5" W x 4" L x 0.25" H
Max: 15" W x 18.5" L x 6" H
- XL26 product range:
Min: 1.5" W x 4" L x 0.25" H
Max: 19" W x 26.5" L x 8" H

FILM

- Film roll diameter: 12"
- 45-70 gauge polyolefin or 1-3 mil low density polyethylene
- XL18 film specifications: 24" max., centerfold, B wind
- XL26 film specifications: 30" max., centerfold, B wind