

Double Roll Closer System

The Fischbein Model DRC 500 Double Roll Closer seals multi-wall, flush-cut paper bags weighing up to 50 pounds at production rates up to 110 linear feet per minute. The Model DRC 500 automatically trims the top of the bag, makes a single precise fold, applies hot melt adhesive, and then makes a final second fold. The patented breakaway design eliminates costly downtime caused by bag jams while allowing easy cleaning and access to the bag folder.



APPLICATIONS

- Fertilizers
- Agricultural Seed
- Feed Additives
- Powdered Dairy Products
- Pet Food
- Cat Litter
- Minerals
- Chemicals
- Snack Foods

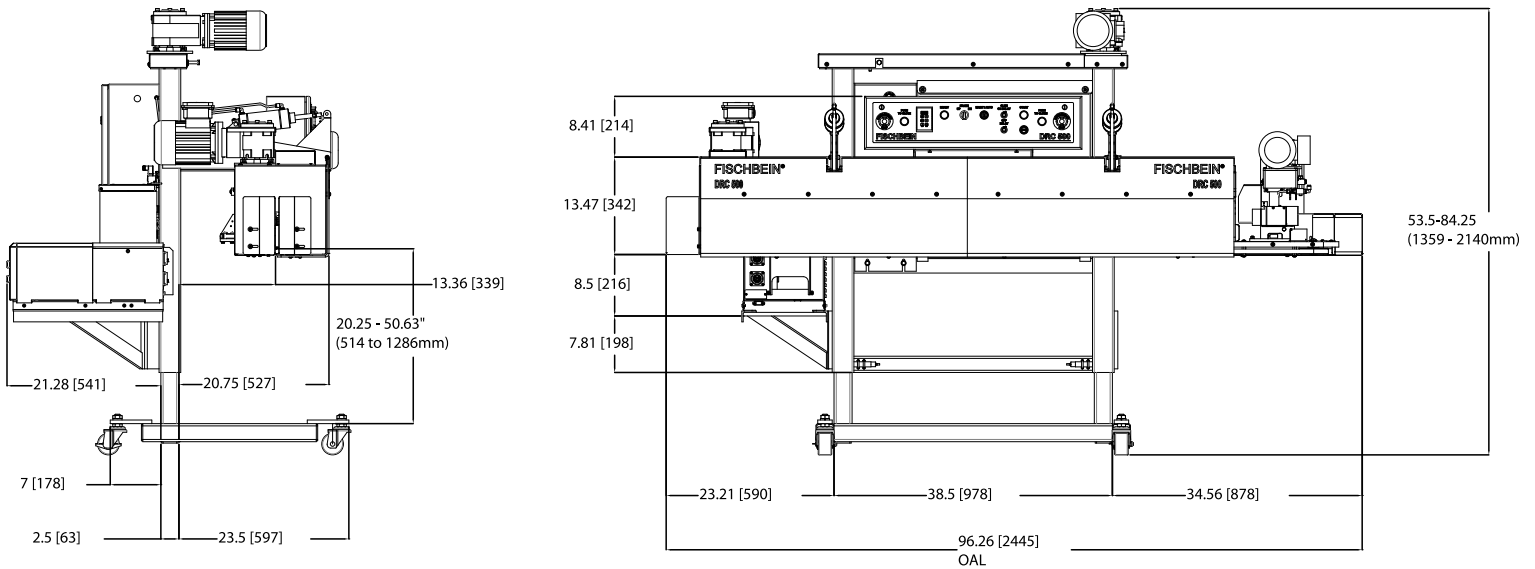

DRC 500

FEATURES

- Closes multi-wall paper bags.
- Spiral glide folder technology creates bag closures that are consistent, reliable and attractive
- A patented breakaway design eliminates costly downtime caused by bag jams, while allowing easy cleaning and service of the bag folder
- Safe and easy to use control panel with digital temperature control and display key pad for variable speed control, and dual emergency stop buttons
- Right to left operation
- Dynatech hot melt adhesive applicator
- Dual knife bag top trimmer

OPTIONS

- Additional motor starter and contractor for conveyor
- Left to right operation
- CR Plus 2 part corrosion resistant
- Nordson brand hot melt application system
- 575 VAC

SPECIFICATIONS

- Dimensions: W 98 in (249 cm), D 47 in (120 cm), H 85 in (216 cm)
- Speed: Up to 110 linear feet per minute
- Electric (NEMA 12): 230V - 3PH - 50/60Hz, 24 VAC
- Air: 8 cfm @ 80-100 PSI

BAGS

- Bag Types: Open mouth flat or gusseted multi-wall paper bags
- Bag Face Width: Minimum 5 in (12.7 cm)
- Free Bag Top: Minimum 6 in (15.2 cm) - standard fold
- Minimum 7.5 in (19 cm) - wide fold