

Automated Bagging System

- Fully Integrated, High Speed, High Volume Bag Handling
- Up to 18 Bags Per Minute

When integrated with an electronic net weigh scale, the Model 3597 automatically picks and positions the empty bag on the filler spout, fills the bag with weighed product, and immediately directs the filled bag to the bag closing station.

The Model 3597 is capable of handling flat or gusseted, multi-wall open mouth paper, plastic, poly, and laminated woven polypropylene bags, as well as all forms of pinch bags.



Shown with Fischbein Brand 500THPS and Optional Bag Kicker and Conveyors

APPLICATIONS

- Agricultural Seed
- Animal Feed & Feed Additives
- Cat Litter
- Chemicals
- Fertilizers
- Minerals
- Pet Food
- Plastic Resins
- And more...

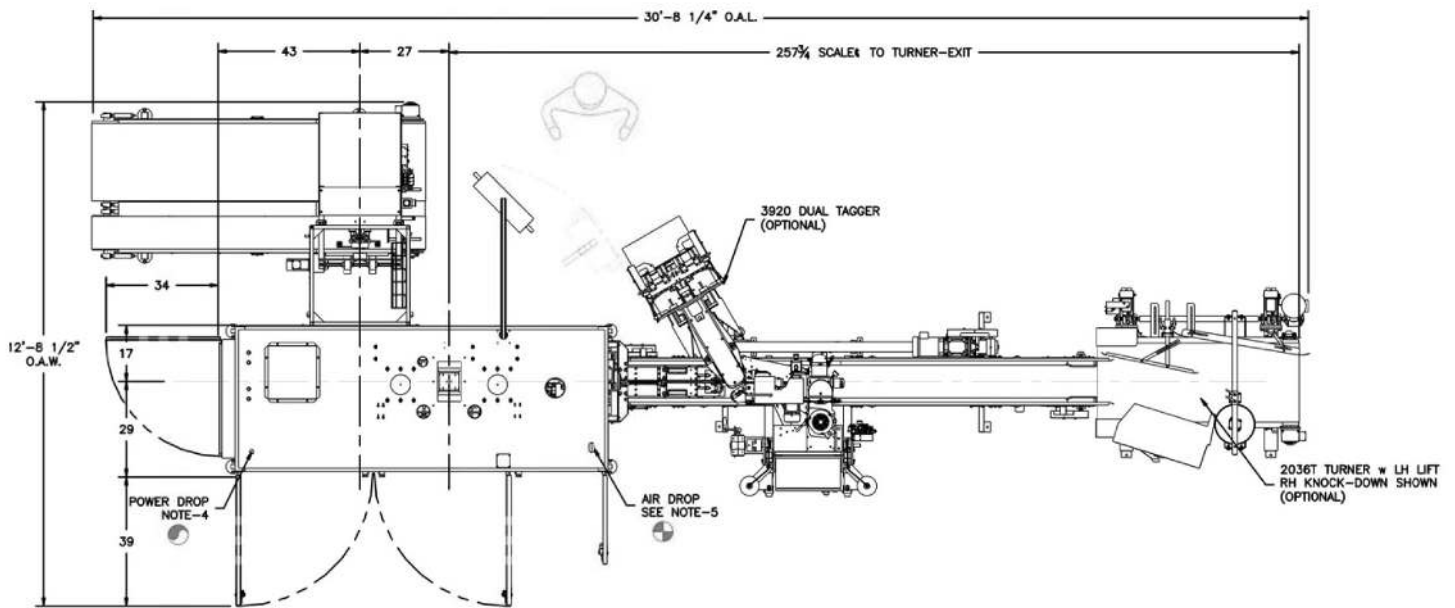

FEATURES

Bag Types

- Processes a variety of pillow or gusseted bags, including multi-wall paper, laminated woven polypropylene and pinch bags.

Fast Product Changeover

- Product change-over is fast, easy, and safe thanks to advanced touch screen controls and motorized adjustments.

Auto Bag Correction

- Auto bag index correction ensures the bag is centered under the spout prior to filling.

No Bag - No Dump Feature

- The "no bag-no dump" feature prevents the machine from releasing product unless the bag is centered correctly, making for minimal product spills.

OPTIONS

- Integrated sealing conveyor
- Enhanced dust control
- Extended bag feed conveyor
- Tagger infeed assembly
- Special anti-corrosion package
- 575 VAC
- Automated tilt tray adjustments
- Data collection and reporting
- Network router

SPECIFICATIONS

Dimensions:

- L 153" (389cm), D 111" (282 cm), H 88-1/4" (224cm)

Note: standard door swing is 39" (99 cm) additional width and electrical enclosure requires 34" (86 cm) in length at rear of machine

Speed:

- Up to 18 bags per minute, product and bag size dependent

Electric (NEMA 12):

- 460 VAC, 3 PH, 60 Hz

Air:

- 45 cfm @ 100 PSI

BAGS

Bag Types:

- Multi-wall paper, laminated woven polypropylene, PE, Pinch, Flat or Gusseted

Bag Thickness:

- Minimum 6 mil

Bag Sizes Min:

- 12"W x 18"L (30.5 cm x 45.7 cm) minimum
- 20" W x 40" L (50.8 cm x 101.6 cm) maximum

Free Bag Top:

- Minimum 6 in (15.2 cm)