

Continuous Motion Shrink Bundler

Our 55GI Model meets the needs of low to medium volume printers and interacts with today's 18,000 to 20,000 books-per-hour binding lines, presorted postal route sequencing applications and the printing industry's fastest counter-stackers.

The 55GI Model is capable of wrapping extremely short, lightweight and random sized products, and is ideal for e-commerce applications. Shrink wrapped bundles reduce movement and product damage during shipment, and provide protection against harmful environmental conditions. This model wraps random sized stacks on demand, without interrupting production of the wrapper itself. The zero tension film feed ensures that this compact and economical shrink bundler wraps up to 55 products per minute.



APPLICATIONS

- Automotive
- Beverage
- Building Supplies
- Consumer Goods
- Contract Packaging
- Food
- Health & Beauty
- Material andling
- Printing & Publishing

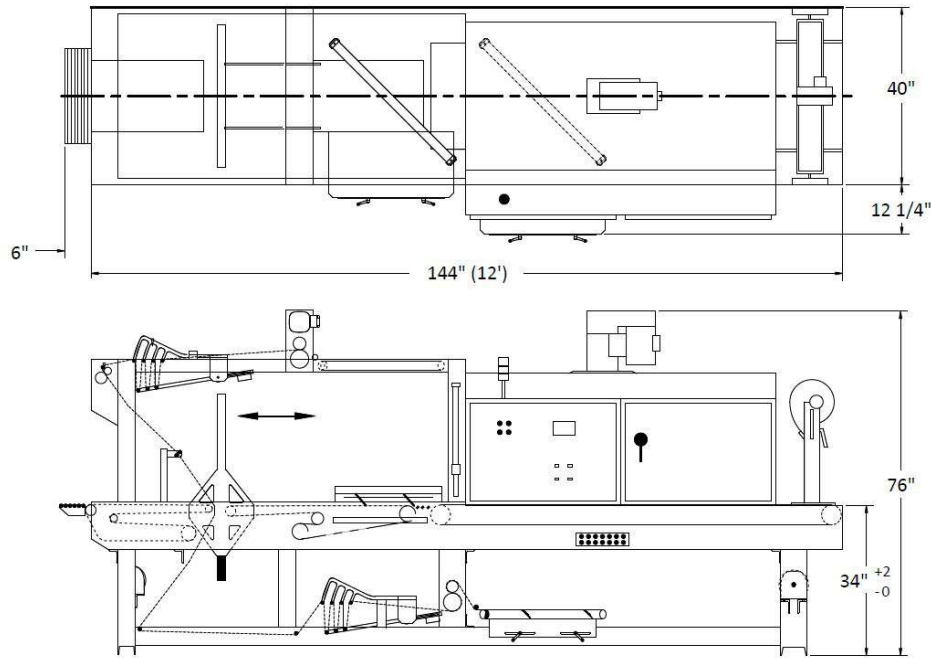

Final layout may vary, 55GI Model.

FEATURES

- Heavy-duty rugged construction designed for high durability and around-the-clock operation
- Compact, single frame design (wrapper with integrated tunnel)
- Laser cut and CNC machined components for maximum precision
- Powder coat finish
- Speeds up to 55 bundles per minute
- Wraps random sized stacks on demand
- Continuous motion seal head provides smooth and quick transitions of product through the wrapper at high speeds
- Quick change plasma-coated seal bars for long life and easy maintenance
- Timing belt stabilized seal frame reduces maintenance and dirt accumulation
- Independent variable speed drives on the wrapper and tunnel
- Zero tension film feed prevents paper sheets or slippery magazines from shingling
- Side mounted film cradles for quick and easy film loading
- Shrink tunnel with product cooling section at the tunnel exit speeds film curing
- Durable Intralox conveyor belts eliminate tracking problems
- Low film alert warns that a film changeover will soon be necessary
- Allen-Bradley® programmable logic controller with standard operator interface
- Digital controls for fast and accurate setup

OPTIONS

- Split belt conveyor allows wrapping of short and lightweight products.
- Collating systems for grouping stacks of products together
- Quick-change seal frame cylinder kit for higher speeds
- On certain high-gloss or stitched products, static charging may be necessary to hold the bundle together while shrink wrapping.
- Casters for machine portability
- Side smoothing rollers to iron out odd shape bull's eyes

SPECIFICATIONS

- Output speed: up to 55 packages per minute
- Electrical: 480V, 3Ph, 60Hz, 40A, 32kW
- Pneumatic: 80 psi, 30 CFM
- Width: 5" to 12"
- Length: 7" to 18"
- Height: 3/16" to 10"
- Film width: 19" max., 6" min.
- Clear or randomly printed
- Film roll diameter: up to 14" with a 3" core
- Optimal film gauge: 1.5 mil. to 2.5 mil.