

## Semi-Automatic Turntable Stretch Wrapper

### FEATURES & BENEFITS

#### Machine Features

- Heavy-duty, welded steel construction (no plastic panels) designed for long life
- Variable turntable speed using 1/2 hp, 90 Vdc motor with ANSI 50 chain drive system, no rubber belts
- Up to 12 RPM rotating table can deliver 25–40 loads per hour
- Long-range photo eye for automatic load height sensing
- Automatic top film over wrap control feature (TOC)
- Adjustable top and bottom illuminated LED wrap counters
- Cycle pause feature
- Electronic film tension adjustment control on control panel
- Manual jog control for turntable
- Eco-friendly, durable, powder coating

#### Film Delivery System

- EZ-Load® film pre-stretch dispenser for 20" film rolls
- Dual anti-static film rollers with manufacturer's lifetime warranty
- Film pre-stretch capability from 150 to 300% stretch (200% standard)
- Variable carriage speed up to 21 feet per minute
- 1/2 hp, 90 Vdc motor with ANSI 40 chain lift drive
- Dancer bar variable-corner compensation
- Electronic film tension adjustment control

#### Controls Hardware

- Allen-Bradley® power, control, and safety components
- Allen-Bradley® MicroLogix™ PLC
- UL/CSA approved components



### APPLICATIONS

- Automotive
- Beverage
- Building Supplies
- Consumer Goods
- Contract Packaging
- Food
- Health & Beauty
- Material Handling
- Printing & Publishing

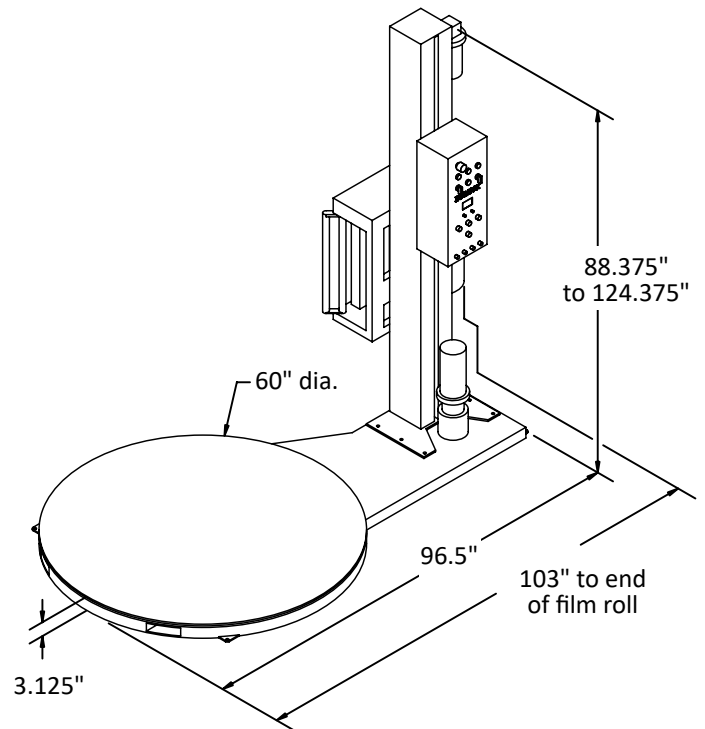
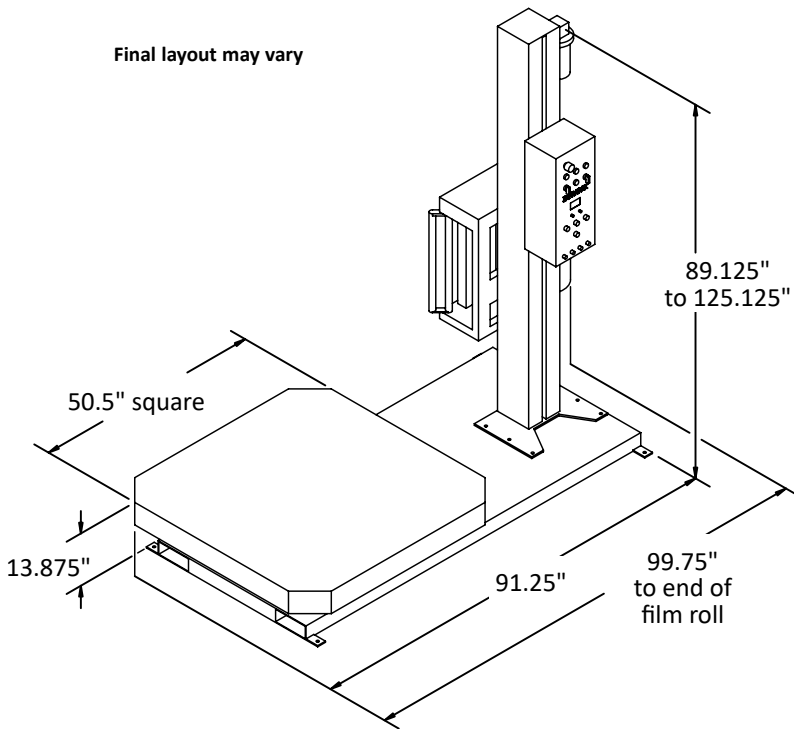

Specification	Measurement
<b>Turntable size – low-profile</b>	60" diameter (standard) 72" diameter (optional) (Larger sizes available)
<b>Turntable size – high-profile</b>	50" square (standard) 50 x 90" rectangular (option)
<b>Max. load diagonal clearance</b>	85" (standard turntable) 102" (optional turntable)
<b>Max. load weight</b>	4,000 lb (standard)
<b>Turntable rotation speed</b>	Up to 12 RPM
<b>Variable carriage speed</b>	Up to 21 FPM
<b>Loads wrapped per hour</b>	25 to 40
<b>Max. load height – low profile:</b> - Standard Tower - Optional extensions available (12, 24, and 36")	81" max load height 93", 105", and 117" option
<b>Max. load height – high profile:</b> - Standard Tower - Optional extensions available (12, 24, and 36")	74" max. load height 86", 98", and 110" option
<b>Electrical power requirements</b>	120 VAC, 1 Ph, 60 Hz, 10 A, 1.2 kW
<b>Standard shipping weight</b>	Low-profile 1,525 lb High-profile 1,260 lb

## OPTIONS

- Extended film towers for wrapping taller loads exceeding standard machine capability
- Top platen device to stabilize tall or light unstable loads during rotation
- Access ramps to assist loading of pallet
- Automatic film tear device (AFTD) tears film at the end of the wrapping cycle
- Split-frame construction to increase film tower clearance for oversized loads
- Cycle counter to count the actual cycles of machine operation
- Extended umbilical cords for split-frame models
- Integrated scale and printer available



Optional Wrap-N-Weigh Operator Display