

NVENIA
A DURAVANT COMPANY

**HAMER BRAND VLR-B
BAGGING AUTOMATION FOR POWDERS**

Introducing Powder Bagging Automation at its Finest

Finally, a fully-automated system that delivers highly accurate dosing of free-flowing powdered products that is easy to clean and operate. Manage filling, weighing, de-aerating, sealing, closing, and conveying in one technologically advanced machine that's proven to eliminate the complexity and challenges of packaging powders.

The VLR-B Powder Bagging Machine provides:

- Highly accurate dosing and multiple dust management measures reduce spills and airborne loss of valuable product
- Rapid changeover and ease of operation maximizes uptime and throughput



POWDER BAGGING CHALLENGES

Bag filling and sealing of fine powders and dusty products present numerous challenges. Unless the process is controlled carefully, unnecessary loss of product and risk can result. Product that escapes during the filling and sealing process leads to material losses and additional costs due to downtime for cleaning and maintenance.

Additionally, depending on the type of product, that powder (or dust) may become airborne and present an explosion or ignition risk. In feed mills, for example, dust should be controlled to safeguard the health of the employees and the environment and to prevent dust explosions. The smaller the dust is, the easier it catches fire, and the more explosive it will be. Additionally, for some products dust can be collected and utilized; for example, feed dust contains many nutrients, such as protein, fat, starch and crude fiber.



nVenia's Hamer brand VLR-B Powder Bagging Machine is specifically designed for the hygienic management and bagging of fine powders, while delivering high accuracy, improved yields, and maximum uptime to operators.



High Accuracy

Perfect weighments
reduce
product giveaways



Improved Yield

Multiple dust
management measures
minimize product loss
and maximize yield



Maximized Uptime

Rapid changeover
Easy to operate and adjust
Easy to clean and maintain

COMMON APPLICATIONS FOR LARGE FORMAT BAGGING OF POWDERED PRODUCTS

Package a variety of powders into large open-mouth bag types, including polyethylene, laminated polypropylene and paper with sealable PE liners. Easy to use touch-screen controls can be programmed for up to 500 recipes.

- Milk powders
- Spices
- Flour
- Calf milk
- Fine minerals
- Breeding
- Bakery mixes
- Whey proteins
- Animal feed additives
- Sugars
- Milled products
- Agricultural powders
- Food coatings
- Ingredients
- Chemicals



Detailed Operation

The Hamer Brand VLR-B Industrial Powder Filling machine is designed to address the challenges of bagging these products in a cost-effective and reliable manner. In the complex world of powder filling, nVenia has simplified the operation and maintenance without sacrificing speed and accuracy. The machine delivers accurate and repeatable weighments while minimizing the production of airborne particulates and dust.

1 It begins with our unique filling mechanism that consists of a feed hopper with a rotating agitator to ensure product is consistently fed to the servo controlled auger filler. The fill spout is equipped with three load cells tied to monitor and accurately time the dosing of product to achieve precise fill weights ranging from 10 lb to 60 lb. The bag is raised up to the spout and gradually lowered as the bag is filled. This reduces the amount of airborne particulate by reducing the distance and rate at which the product enters the bag.

2 During filling, vacuum ports on either side of the filler capture any dust that does escape. From there, the bag is moved to a de-aeration stage where probes enter the product and extract air that is entrained, improving the rigidity and stability of the completed bag.

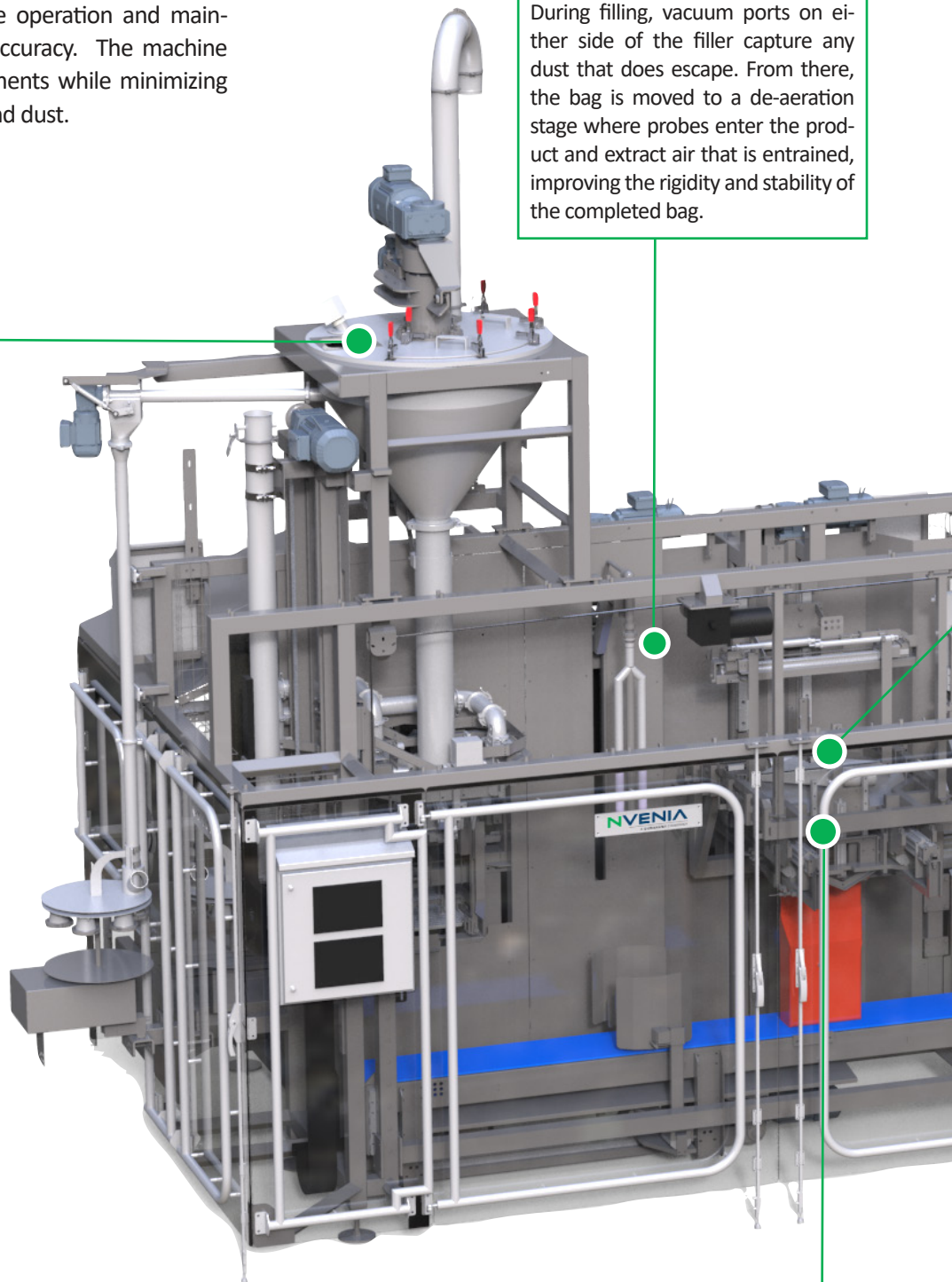

4 An impulse sealer creates a sift-proof seal across the opening of the bag or inner liner. Additional dust extraction vacuum ports are incorporated at this stage.





3
The top of the bag is stretched and cleaned before any air above the product is squeezed from the bag top to prepare it for sealing.

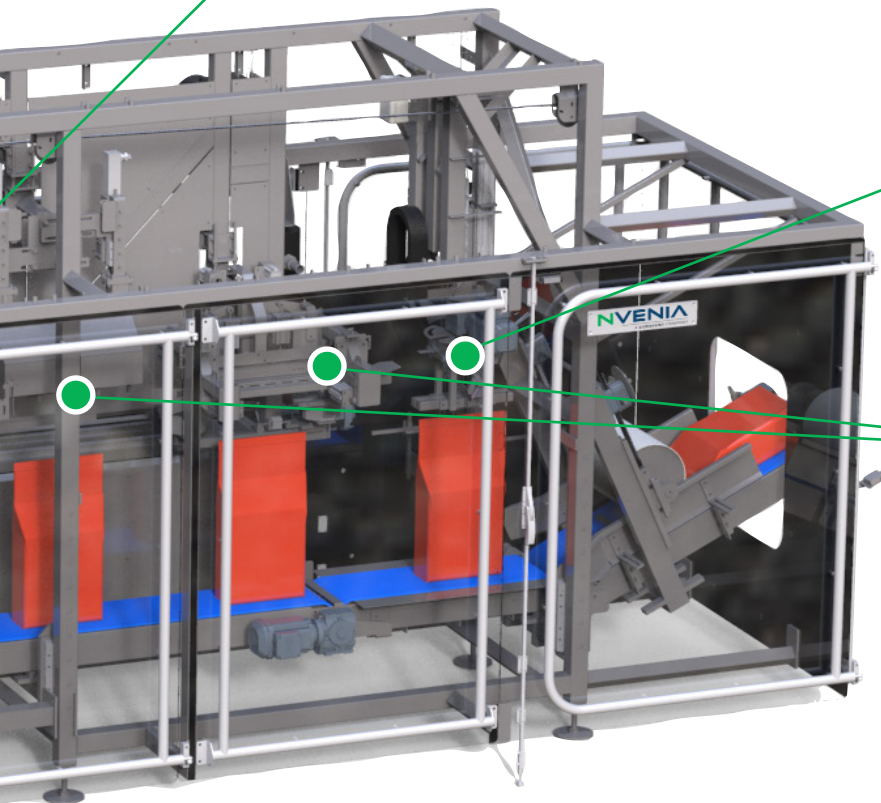

6
Bag is then turned and laid flat before exiting the machine

5
The bag can then enter either a bag folder/heat sealer to activate the bag top glue strip or a sew system that can apply crepe tape and stitching to bring the bag to a pallet ready shape.

DESIGNED FOR THE OPERATOR - EASY TO USE AND EASY TO MAINTAIN

The design of the entire machine is built to minimize maintenance and accumulation of dust. The entire machine is elevated on pedestals to facilitate cleaning. All product filling, sealing and handling stations are suspended from the powder coated machine frame, reducing the number of product collection surfaces. All welds and penetrations are fully executed to enhance hygiene and any frame members that sit beneath the product flow are rotated 45 degrees to eliminate any horizontal landing surfaces. The touchscreen operator interface uses simple to understand graphics and icons to help define and select one of up to 500 product recipes. And all product contact surfaces are fabricated of 304 stainless steel.

Additional features and options are available to match your specific application, such as: additional bag loading stations, centralized dust extraction, bag top trimmer and aligner, ATEX rated zone around the filler spout, integrated labeler, integrated check weigher with rejection station, gas flushing, and more.

Specifications

FEATURES

- Highly accurate, servo controlled dosing
- Dust collection/management at each stage in the process
- Bottom up fill method to minimize generation
- Up to 500 programmable recipes
- Ethernet and Wi-Fi connections for remote service
- Easy to clean structure built with hygienic design principles
- Designed for ease of operation, adjustment, and maintenance
- Fully welded, powder coated, structural steel frame
 - product contact points in 304 Stainless Steel



SPECIFICATIONS

- Up to 6 bags per minute - product and bag size dependent
- Minimum 10 lb, maximum 60 lb product weight
- 0.6 to 0.8 kg/L powder density
- 480VAC, 3 Phase, 60 Hz
- 90 PSI air with 1.5" connection
- Full color touchscreen HMI
- CE compliant construction
- 304 Stainless Steel product contact points
- RAL9007 paint color



OPTIONS

- Integrated bag top correction and pinch-top sealer with tape closure
- Integrated bag top sewing system with bag top cutter and crepe tape
- ATEX around filling point (3 foot radius)
- Additional stack stations for empty bags
- Integral product sampling unit to extract samples from the dosing hopper
- Bag top trim removal
- Gas flushing with nitrogen
- Centralized dust extraction - combines all dust extraction zones to single outlet
- Full 304 Stainless Steel construction
- Post fill in-line check weigher with reject station
- Post fill in-line metal detector
- Post fill in-line X-ray machine
- Integrated label printer
- Remote located electrical controls



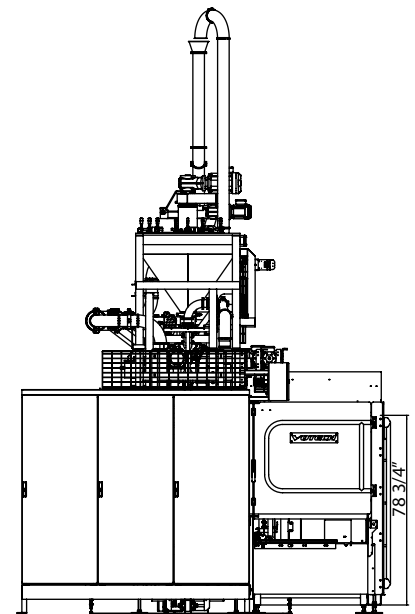
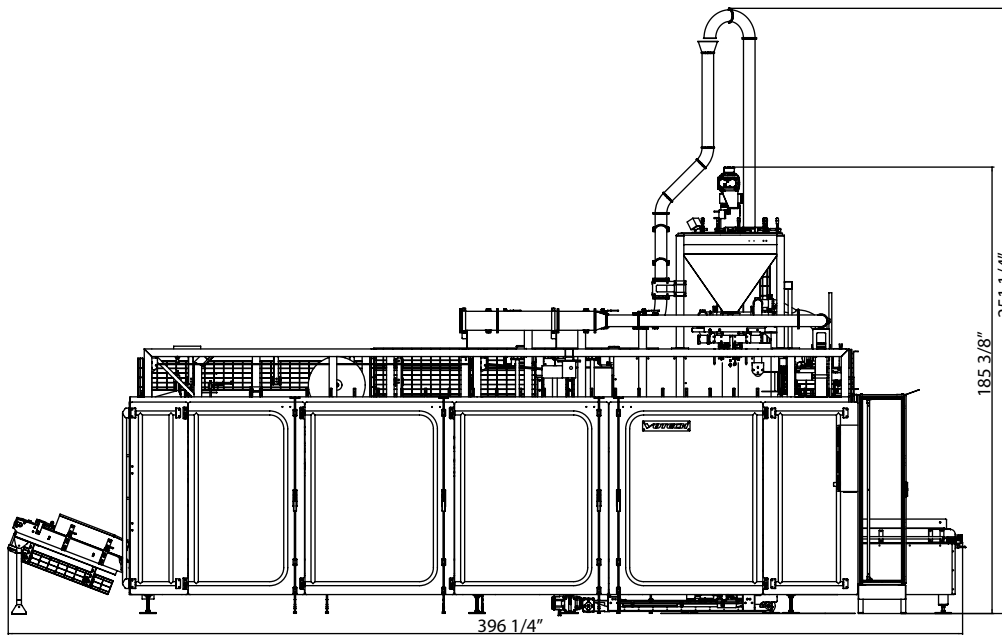
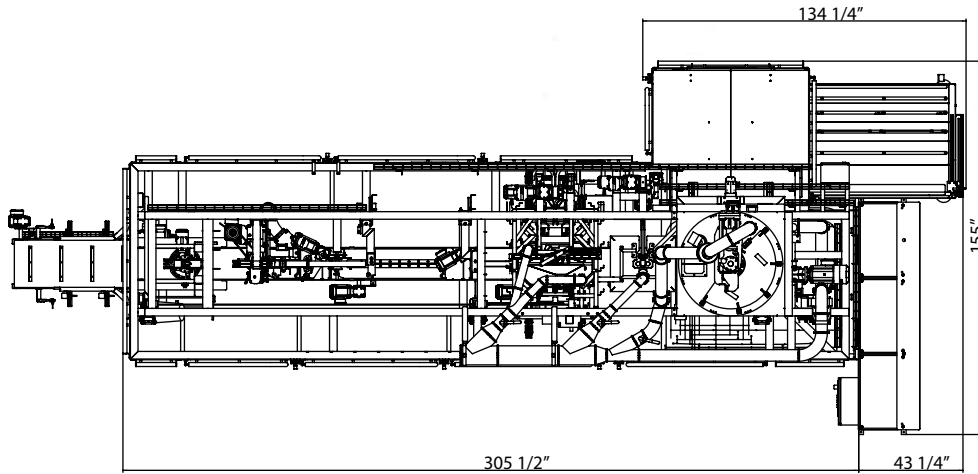

BAG INFORMATION

- L 23-5/8" (600 mm) to 39-3/8" (1000 mm)
- W 15" (380 mm) to 22-1/2" (570 mm)/17-3/4" (450 mm) with gusset (Note: gussets will be inverted during sealing)
- Open mouth paper with sealable PE liner (min 7 mil), laminated polypropylene, polyethylene, block bottom style with pillow top is preferred





NVENIA

750 N. Wood Dale Road
Wood Dale, IL 60191
info@nVenia.com
800.253.5103
www.nVenia.com

SUPPORTPRO

3500 Lacey Road, Suite 290
Downers Grove, Illinois 60515
support@supportpro.pro
844.777.8776
www.supportpro.pro