

### Intermittent Motion Shrink Bundler

Our ARPAC Brand 708HB Model is a right-angle, intermittent motion shrink bundler designed specifically for today's pharmaceutical, health and beauty industries.

Ultra-compact in design and economical in price, the 709HB Model is capable of shrink wrapping up to 20 bundles per minute in a single lane configuration. This model uses motorized pulleys rather than separate drives an chain,. This allows for clean, safe operation and a slim machine frame.



#### APPLICATIONS

- Beauty products
- Vials
- Cosmetics
- Spices
- Glass bottles
- Spray cans
- Boxes
- Plastic bottles

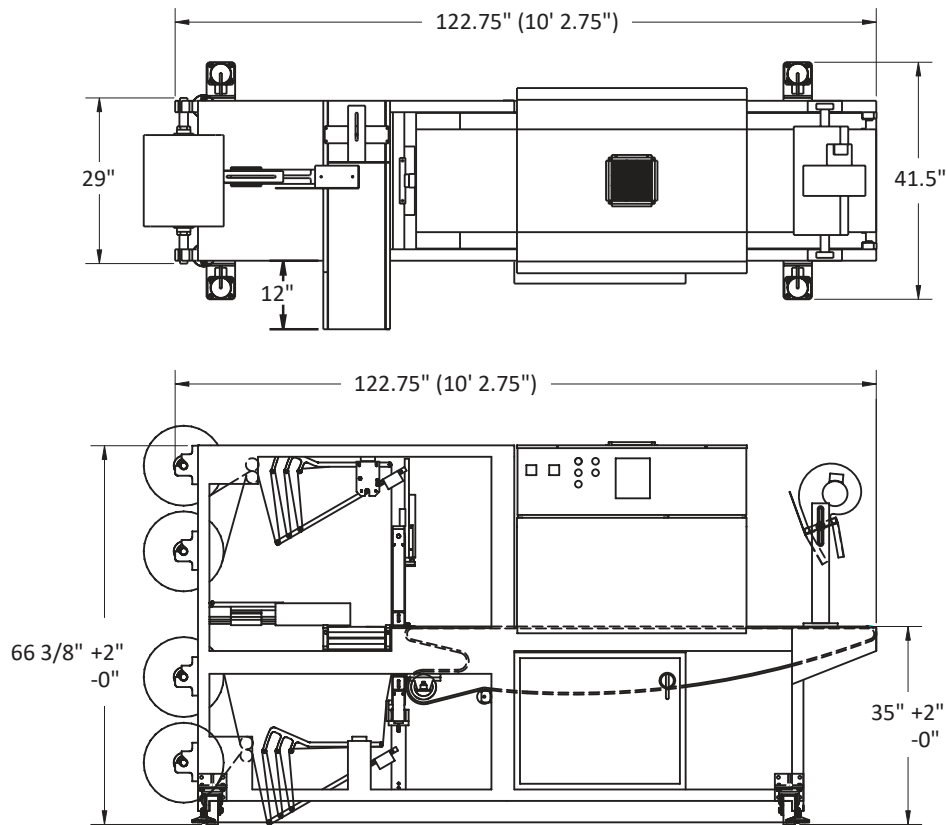

Final layout may vary.

## FEATURES

- Compact single-frame stainless steel construction
- Heavy-duty system for 24/7 operation
- Simple setup and tool-less changeovers for ease of use and minimal downtime
- Low maintenance conveyor belts do not require tracking adjustments
- Motorized pulleys eliminate chain drives and operate more cleanly, with reduced maintenance cost and less noise
- Quick-change seal bar with military-type quick disconnect
- Top and bottom film racks accommodate four 14" diameter rolls of film
- No lubrication required for clean and easy maintenance

## OPTIONS

- Turbo cooling for quick product handling after shrink tunnel
- Servo driven main ram
- Standard or custom infeeds

## SPECIFICATIONS

- Speed: up to 20 packages per minute
- Electrical power requirements: 208, 230 or 460 VAC, 3 Ph, 60 Hz
- Compressed air requirements: 8 SCFM @80 psi
- Film roll diameter: 14" maximum with 3" core
- Film gauge: 3 mil.

## PRODUCT RANGE

- Minimum: 3/4" W x 3/4" x 1/2" H
- Maximum: 6" W x 11" L x 8" H