

Band Sealer

The Fischbein B2600 continuous band sealer is designed for high production industrial bagging operations closing polyethylene and polypropylene gusseted bags, pillow bags, and pouches at up to 60 linear feet per minute. This low maintenance band sealer features forced air cooling of seal for downstream handling, a removal sealing section for easy maintenance and cleaning access, quick belt replacement design, user friendly controls with easy to read digital temperature display, an adjustable height pedestal, and NEMA 12 rated electrics. Standard lead time 4-6 weeks.



APPLICATIONS

- Bakery Mixes
- Fertilizers
- Powdered Dairy Products
- Minerals
- Agricultural Seed
- Pet Food
- Chemicals
- Feed Additives
- Cat Litter

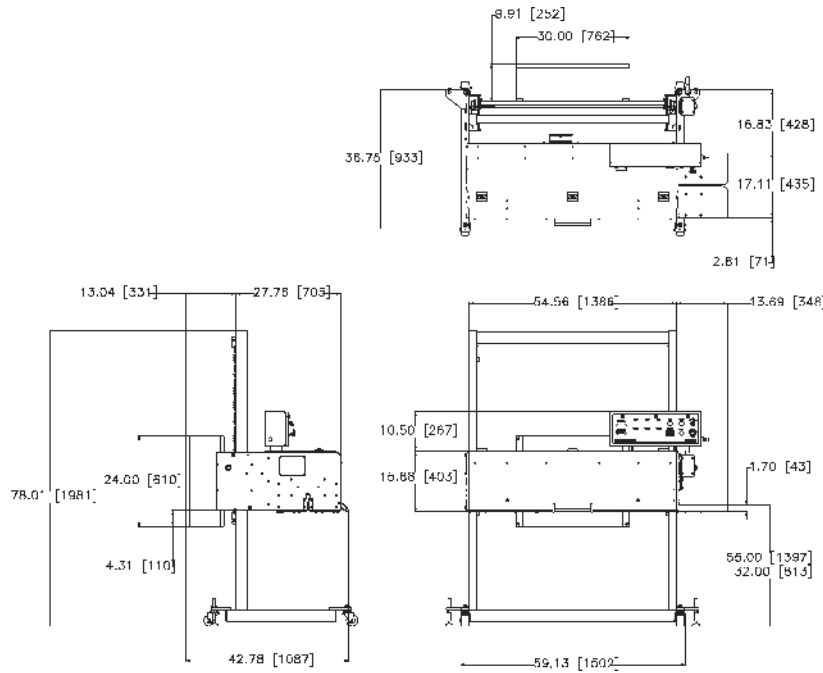

Final layout may vary.

FEATURES

- Sealing width: ¼" wide (sealing widths up to ½" wide available)
- Digital temperature display in Fahrenheit/Centigrade
- 13" belt driven infeed
- Right to left operation direction
- Adjustable sealing height from 32.5 inches to 56.5 inches
- Variable speed drive, up to 60 linear feet per minute
- Automatic temperature shut down
- NEMA 12 rated electronics
- Standard voltage – 230 volt / 3 phase / 60 Hz
- Teflon fiberglass sealing bands
- Heat bars: two pair (14.38")
- Cooling bars for downstream handling
- Variable speed drive
- Digital temperature control

SPECIFICATIONS

- Bag type: polyethylene and polypropylene
- Dimensions: 78"H x 75"L x 44"D
- Shipping weight 620 lbs.
- Electric: 230V / 3Ph / 60Hz
- FLA: 9.0
- Speed: up to 100 linear feet per minute

OPTIONS

- Bag top trimmer
- Airwash bag top air clean + top trimmer
- Water cooling system
- Motorized height adjustment
- Additional creaser wheels:
 - 1/4"
 - 3/8"
 - 1/2"
- High resolution inkjet printer
- Embossing coder
- Numbers kit
- Letters kit
- Additional temperature controller
- Additional temperature controller package
- Conveyor control, VFD (1 HP)
- Heater fault light
- Left to right feed direction
- 460 V / 3 Ph / 60 Hz
- 575 V / 3 Ph / 60 Hz