

Hot Air Sealer

The Fischbein Model HAS 300 Hot Air Sealer is a high-production sealing system that efficiently closes a wide range of heat sealable pillow-type and gusseted bags at up to 100 linear feet per minute. Easily adjustable controls for the heaters, air flow, and carry through belts ensure consistent, sift proof sealing for a variety of bag sizes and thicknesses. There are NO BANDS required to seal gusseted bags, eliminating maintenance cost and downtime.



APPLICATIONS

- Bakery Mixes
- Fertilizers
- Powdered Dairy Products
- Minerals
- Agricultural Seed
- Pet Food
- Chemicals
- Feed Additives
- Cat Litter

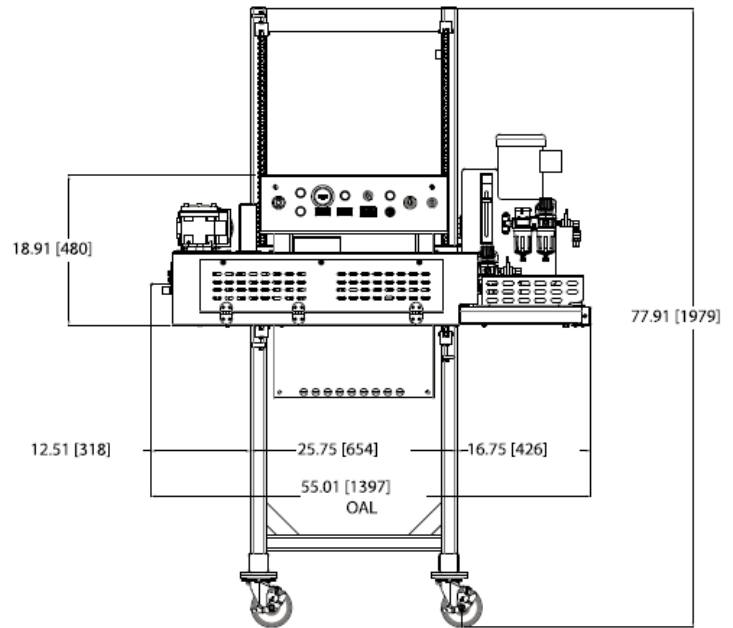
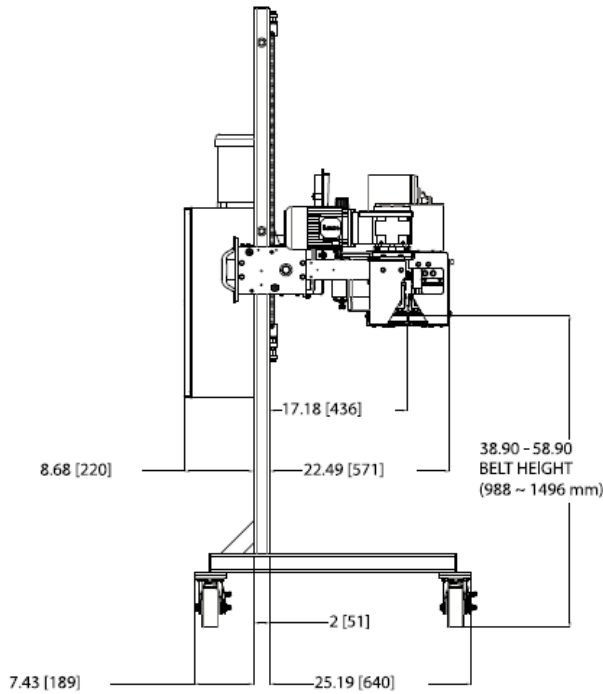

HAS300 - HP

FEATURES

- **Bag Types:** Seals pillow and gusseted style polyethylene bags without the use of bands.
- **Consistent, Continuous Production:** Dual VFDs provide synchronous compression wheel and carry through belt speed control. The result - strong, sift-proof closures, every time.
- **No Bands:** Eliminate maintenance costs and downtime - no bands required to seal gusseted bags.
- **User Friendly Controls:** Safe and easy to use control panel with digital temperature display, key pad for variable speed control, and dual emergency stop buttons.
- **Quick Changeover:** Motorized height adjustment. Digital display compression force and heat manifold pressure.

OPTIONS

- Left to right operation
- Motor starter and contactor for conveyor
- Air wash system with high performance bag top trimmer
- CR Plus 2 part corrosion resistant powder coat finish
- Stainless Steel NEMA 4 washdown model

SPECIFICATIONS

- Dimensions: L 55 in (140 cm), D 34 in (86 cm), H 79 in (201 cm)
- Speed: 30 to 100 linear feet per minute
- Electric (NEMA 12): 230/380/460 VAC, 3 PH, 50/60 Hz
- Air: 10 cfm @ 60 PSI

BAGS

- Bag Types: Heat sealable structures in pillow and gusseted bags.
- Bag Thickness: Maximum 10 mill
- Free Bag Top: Minimum 6 in (15.2 cm)