

### Tape Sew

The Fischbein Brand Model 400 TNS™ is a tape over sew system designed for bagging applications up to 55 linear feet per minute. It is used to seal multi-wall paper and laminated woven polypropylene open mouth bags, producing an attractive crepe tape sewn bag closure.

The Model 400 TNS™ automatically trims the top of the bag, applies the tape, sews the bag closed and lastly cuts the crepe tape and thread at the completion of each sewing cycle.



Model Shown with Filler Cord



#### APPLICATIONS

- Fertilizers/Minerals
- Bakery Mixes
- Agricultural Seed
- Cat Litter
- Chemicals
- Powdered Dairy Products
- Feed Additives
- Pet Food

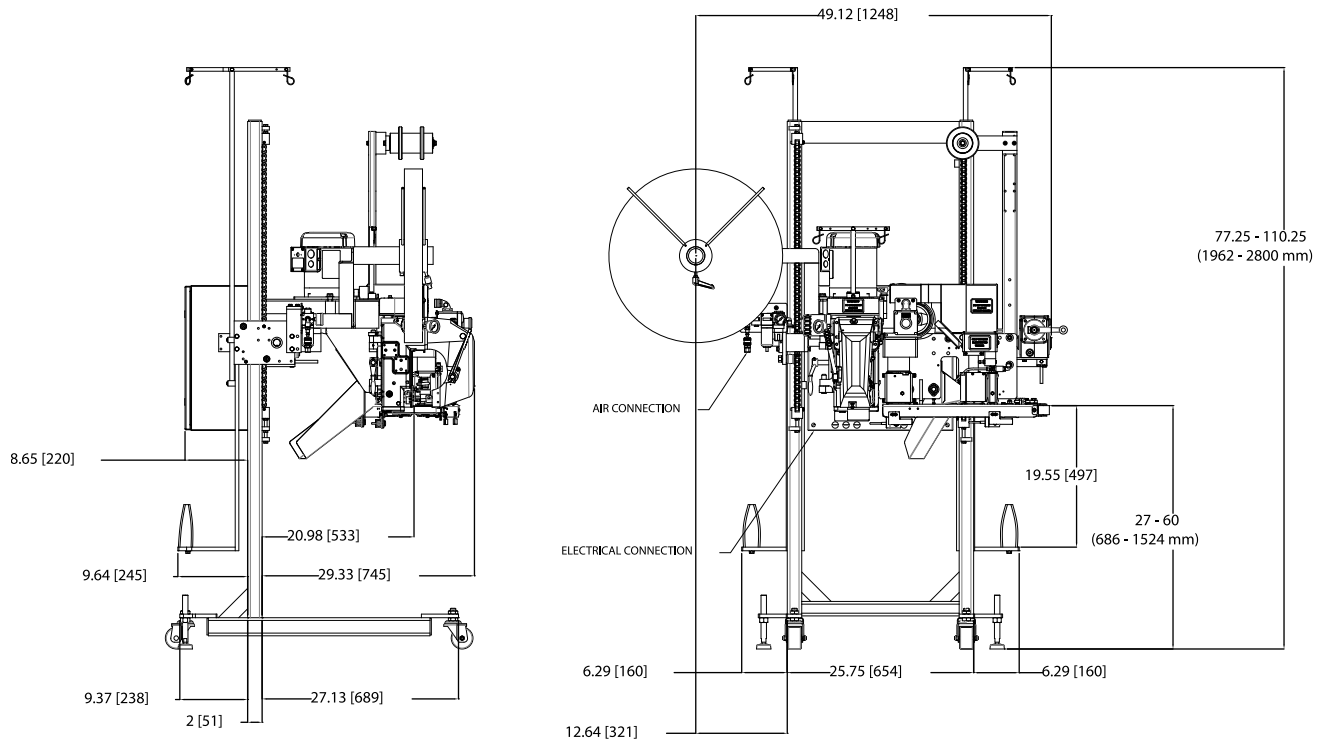

**FEATURES**

**Bag Types**

Multi-wall paper and laminated woven polypropylene, open-mouth bags.

**Empress 101 Sewing Head**

With its self-lubricating system, the Empress 101 delivers trouble-free smooth performance with low vibration. Operating speed is adjustable up to 55 linear feet per minute.

**Bag Top Trimmer**

Specifically designed with quick change, long life blades that ensure thousands of hours of trouble-free operation on both paper and laminated woven poly bags.

**Tape & Thread Cutter**

Activated by a PLC-controlled photoelectric eye, this pneumatic system automatically cuts the crepe tape and thread at the completion of the sewing cycle.

**OPTIONS**

- Direct drive VFD package for synchronous sewing
- Motor starter and contactor for conveyor
- Tagger infeed
- Tape, Thread and Oil Sensor package
- Tape contact coder (P2375)
- Filler cord
- High performance tape and thread cutter
- 575 VAC

**SPECIFICATIONS**

- Dimensions: L 49 in (124 cm), D 41 in (104 cm), H 78 in (198 cm)
- Speed: Up to 55 linear feet per minute
- Electric (NEMA 12): 230/380/460 VAC, 3 PH, 50/60 Hz
- Air: 10 cfm @ 90 PSI

**BAGS**

- Bag Types: Multi-wall paper and laminated woven polypropylene open mouth bags
- Bag Thickness: Maximum 12 mils
- Free Bag Top: Minimum 6 in (15.2 cm)