

### Sewing Automation

The Fischbein 501 T is the latest in Hamer-Fischbein sewing technology. Our new top of the line tape sewing system includes many features that will improve productivity.

- New, intuitive HMI interface.
- PLC and servo motor eliminates need for clutch/brake with speeds adjustable through the HMI.
- Improved powered crepe tape feed system.
- New easy to adjust infeed.
- Improved thread control.

The 501 T closes multi-wall paper, and laminated woven polypropylene open mouth bags at speeds up to 75 linear feet per minute.



#### APPLICATIONS

- Fertilizer/Minerals
- Chemicals
- Cat Litter
- Pet Food
- Feed Additives
- Agricultural Seed
- Bakery Mixes
- Powderd Dairy Products

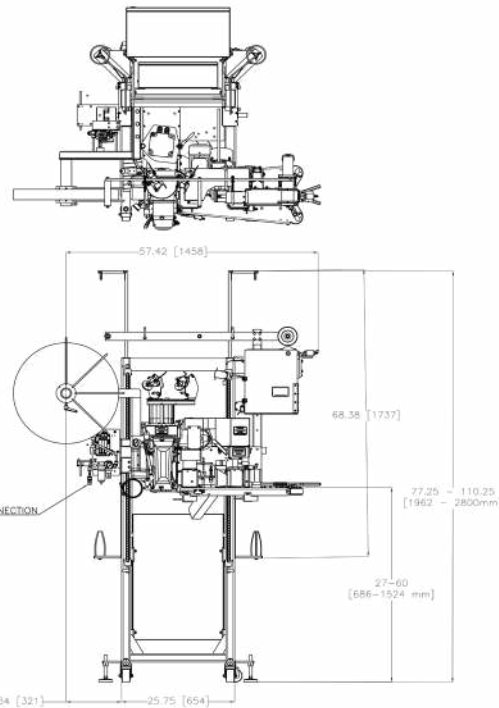
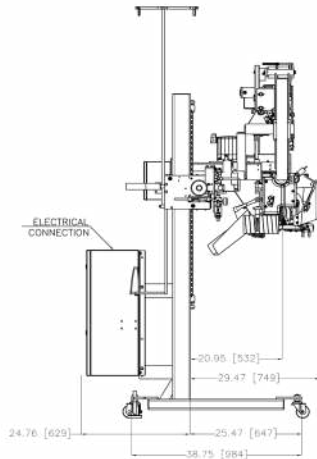

LAYOUT FOR 501T SEWING SYSTEM  
 REVISION 1  
 32" INFEED  
 4/22/2020

## FEATURES

- **Bag types:** Closes a variety of bags including flat and Gusseted multi-wall paper, and woven polypropylene bags.
- **Empress 201 sewing head:** With its's self-lubricating system, the Empress 201 delivers trouble-free smooth performance with low vibration. Operating speed is adjustable up to 75 linear feet per minute.
- **Bag top Trimmer:** Specifically designed with quick change, long life blades that ensure months of trouble-free operation.
- **Speed Settings:** Head and infeed speeds are set via HMI. A timing belt between the sewing head and motor ensures consistent, drift-free control.
- **Come Standard With:** New, intuitive HMI interface, improved powered crepe tape feed system, easy to adjust infeed, and improved thread control. The PLC and servo motor eliminate the need for a clutch/brake.

## OPTIONS

- Tragger infeed
- Tape contact coder (P2375)
- Motor starter and contactor for conveyor

## SPECIFICATIONS

- Dimensions: L 58" (147cm) D 41" (104cm) H78" (198cm)
- Speed: Up to 75 linear feet per minute
- Electric (NEMA 12): 230/380/460 VAC, 3 PH, 50/60 Hz
- Air: 15 cfm @ 90 PSI

## BAGS

- Bag Types: multi-wall paper and laminated woven polypropylene open mouth bags.
- Bag Thickness: maximum 125 mils
- Free Bag Top: minimum 6" (15.2cm)