

Hot Air Sealer

The Fischbein Model HAS 220 Hot Air Sealer provides efficient, cost effective sealing of pillow style or bottom gusset pre-made polyethylene bags up to 60 feet per minute. Standard DC variable speed controls synchronize sealer to conveyor speeds.



BAGS

- Bakery Mixes
- Fertilizers
- Powdered Dairy Products
- Minerals
- Agricultural Seed
- Pet Food
- Chemicals
- Feed Additives
- Cat Litter

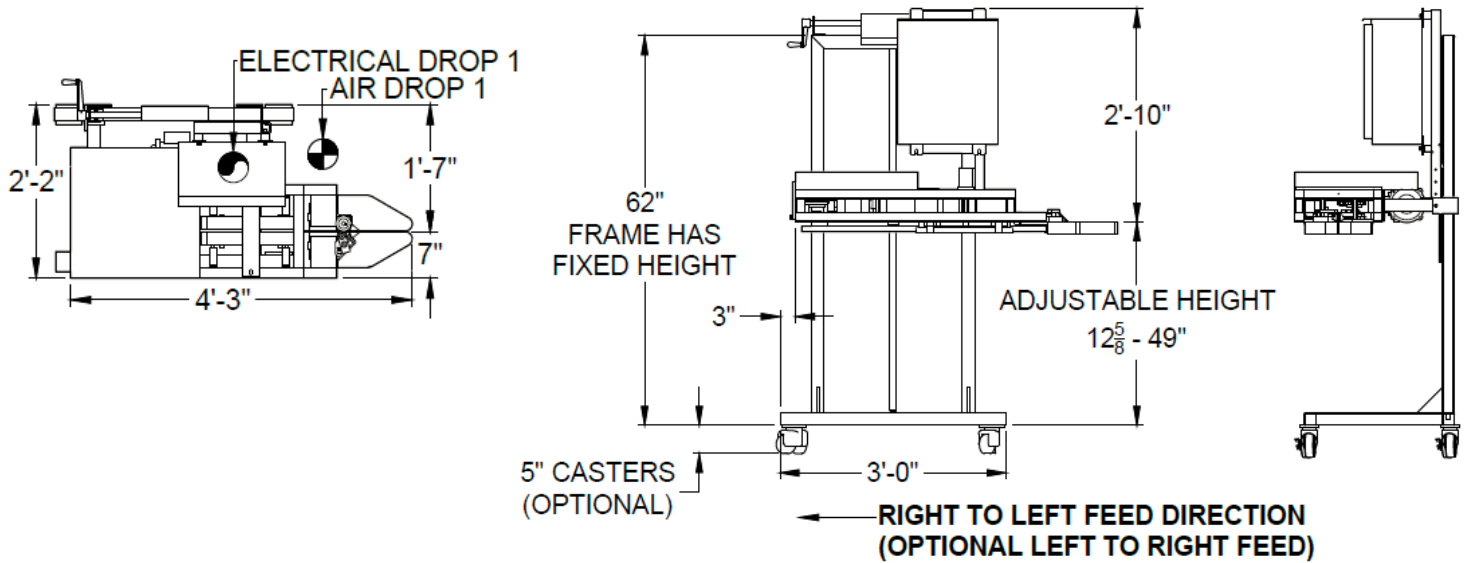

FEATURES

- Bag Types: Seals pillow style, non-side gusseted bags without the use of bands.
- Consistent, Continuous Production: Standard DC variable speed controls match sealer and conveyor speeds for maximum bag production.
- No Bands: Eliminate maintenance costs and downtime - no bands required.
- User Friendly Controls: Safe and easy to use control panel with digital temperature display, air pressure detector, and automatic heater burnout detector to ensure seal quality.

OPTIONS

- Industrial casters for portability
- Left to right operation
- Extra heat
- Seal Cooling
- Embossing Coder

SPECIFICATIONS

- Dimensions: L 36 in (91.4 cm), D 26 in (66 cm), H 62 in (157.5 cm)
- Speed: Up to 60 linear feet per minute
- Electric (NEMA 12): 230 VAC-1PH-60 Hz, 23 FLA
- Air: 6 cfm @ 80 PSI. Up to 10 cfm with Cooling Option.
- Weight: 550 lb (uncrated)

BAGS

- Bag Types: Heat sealable structures in a wide range of poly bags.
- Bag Thickness: Min. 2 mils; Max. 8 mils